

E-Truck 2000

2000kg



Large **li-ion battery** and powerful **1.6kW drive motor**: can be used on ramps & inclines

Support castor wheels for excellent stability and gradeability on **uneven & sloping surfaces**

Fast charge lithium ion battery, on board charger: can be opportunity charged between transports

Ultra slim design with short chassis length and small turning radius: perfect for **confined spaces**

Creep speed for slow, precise handling in very confined areas

1 year **on-site** parts & labour warranty (UK mainland)



E-Truck 2000 Specification

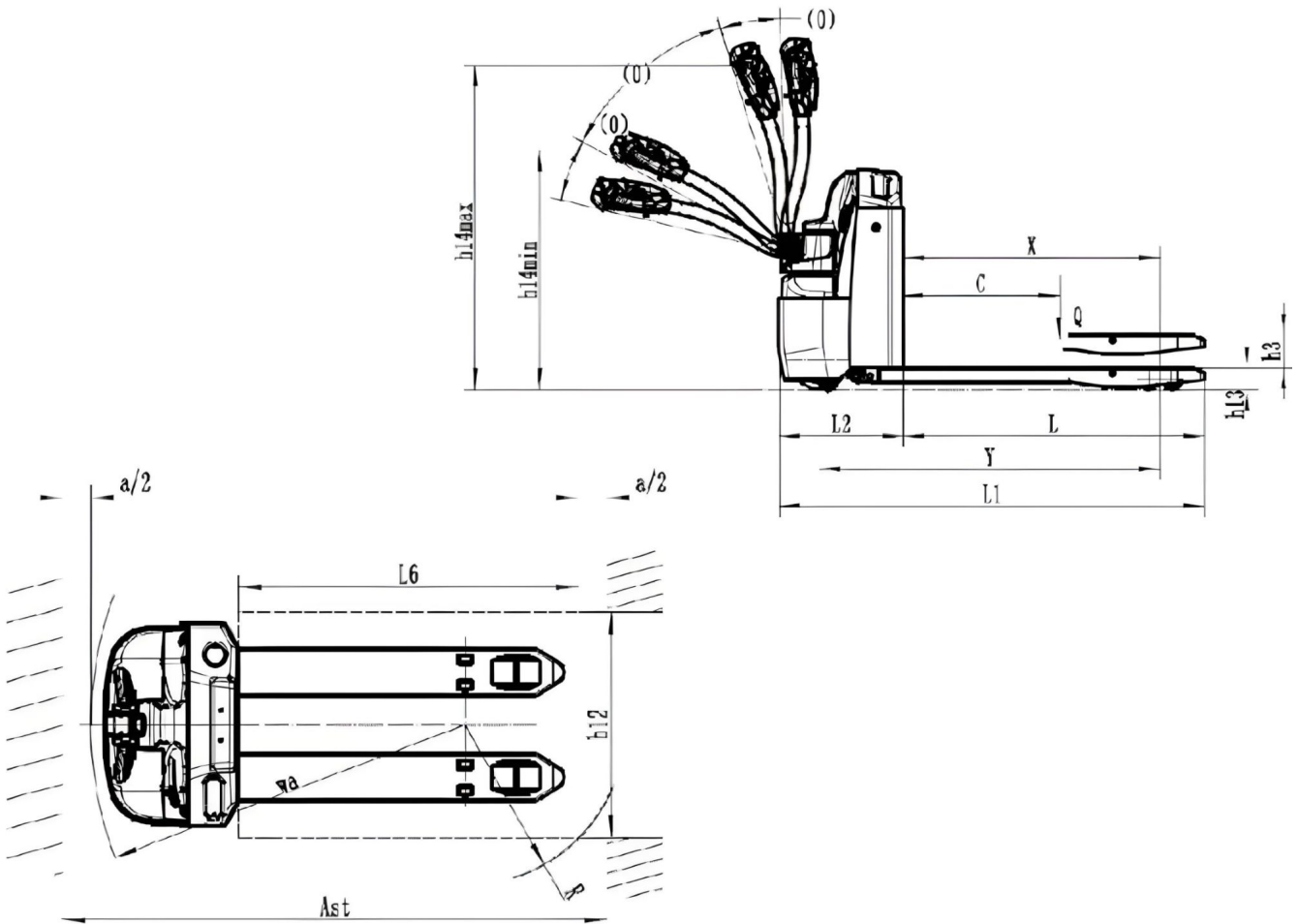

Lift Type	Fully Powered	Outside Fork Width (s)	550mm
Load Capacity Q	2000kg	Fork Length (l)	1150mm
Truck Service Weight	280kg	Aisle Width, 1000 x 1200 UK pallet crossways (Ast)	2153mm
Ground Clearance, Centre of Wheelbase (m2)	27mm	Aisle Width 800 x 1200 Euro pallet lengthways (Ast)	2080mm
Wheels	Polyurethane	Turning Radius (Wa)	1320mm
Forks Lowered (h13)	82.5mm	Travel Speed With / Without Load	5 / 5.6 kmh
Forks Raised (h13 + h3)	207.5mm	Maximum Gradeability With / Without Load	8 / 16 %
Overall Length (l1)	1620mm	Drive Motor Rating S2 60 min	1.6 KW
Overall Width (b1 / b2)	714mm	Battery Voltage / Nominal Capacity	24V / 100Ah

Workplace Handling Solutions

Units 10 & 11 Bridgwater Court, Oldmixon Crescent, Weston-super-Mare BS24 9AY

Tel: +44 (0)1934 621777 Email: sales@howardhandling.co.uk Web: howardhandling.co.uk