

Can be adjusted for two-points or three points clamping

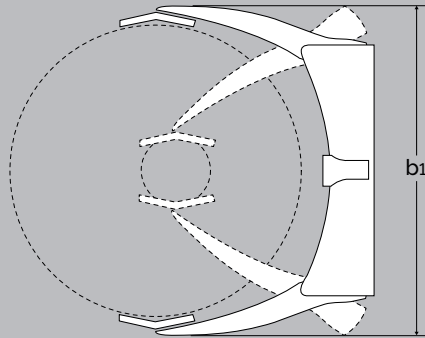

Two-points clamping

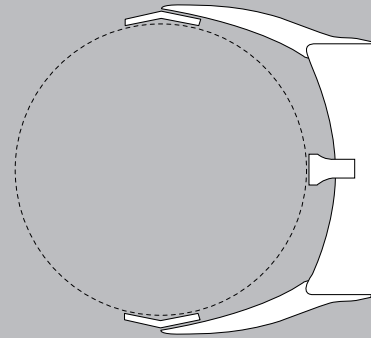

Three-points clamping

PRODUCT (measured in mm)		LFRRM 1001	ELFRRM 1001	ELFRE 1001	SELFRE MAXI 1003	SELFREP MAXI 1003
Capacity in kg		500 kg	500 kg	500 kg	500 kg	325 kg
Reel diameter - two-points clamping		120-1270				
Reel diameter - three-points clamping		800-1270				
Opening gripping arms		Max 1300				
Lifting height	$h_3$	1750				
Overall height	$h_1$	1925			1930	
Overall width	$b_1$	980				
Overall width gripping arms min.	$b_{1-1}$	1150				
Overall width gripping arms max.	$b_{1-2}$	1445				
Width between legs	$b_4$	285				
Overall length	$l_1$	1620	1730	1730	1795	
Lowered height	$l_{13}$	225				
Rotation height	$h_{13}$	Min 825				
Gangway	$A_{st}$	2290*			2200*	
Turning angle of wheels		210°				
Driving motor					1,2 kW 24 V**	
Driving speed with/without load					Below 500 mm lift: 5/6 km/h, over 500 mm lift: 3/4 km/h	
Pump motor			1,1 kW 12 V	1,1 kW 12 V	1,2 kW 24 V	
Lifting speed with / without load	Normal/quick: 8/26 mm per pump		0,05 / 0,07 m/s	0,05 / 0,07 m/s	0,07 / 0,12 m/s	
Lowering speed with / without load	Max 0,05 m/s - Max 0,07 m/s		0,12 / 0,04 m/s	0,12 / 0,04 m/s	0,12 / 0,07 m/s	
Weight in kg (no battery)		380 kg	410 kg	410 kg	480 kg	485 kg

\* tests show that 1700 mm are enough.

\*\* speed control electronically variable.