

Can be adjusted for two-points or three points clamping

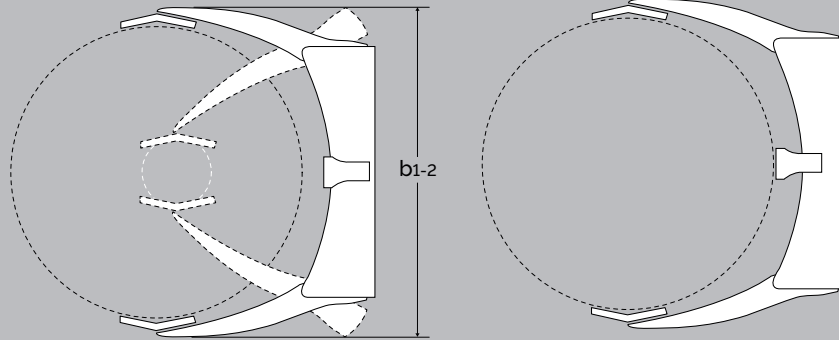

Two-points clamping

Three-points clamping

| PRODUCT (measured in mm) | | LFSRRM 1001 | ELFSRRM 1001 | ELFSRRE 1001 | SELFSRRE MAXI 1003 | SELFREP MAXI 1003 |
|---------------------------------------|-----------|---|-----------------|-----------------|-----------------------|--|
| Capacity in kg | | 500 kg | 500 kg | 500 kg | 500 kg | 325 kg |
| Reel diameter - two-points clamping | | 120-1270 | | | | |
| Reel diameter - three-points clamping | | 800-1270 | | | | |
| Opening gripping arms | | Max 1300 | | | | |
| Lifting height | h_3 | 1750 | | | | |
| Overall height | h_1 | 1925 | | | 1930 | |
| Overall width | b_1 | 166 + b_4 (min 1130 mm) | | | | |
| Overall width gripping arms min. | b_{1-1} | 1150 | | | | |
| Overall width gripping arms max. | b_{1-2} | 1445 | | | | |
| Width between legs | b_4 | 850 - 942, 942 - 1124, 1124 - 1306, 1240 - 1422 | | | | |
| Overall length | l_1 | 1585 | 1705 | | 1760 | |
| Lowered height | h_{13} | 225 | | | | |
| Rotation height | | Min 750 | | | | |
| Gangway | A_{st} | 2290* | | | 2200* | |
| Turning angle of wheels | | 210° | | | | |
| Driving motor | | | | | | 1,2 kW 24 V** |
| Driving speed with/without load | | | | | | Below 500 mm lift: 5/6 km/h, over 500 mm lift: 3/4 km/h |
| Pump motor | | | 1,1 kW 12 V | 1,1 kW 12 V | 1,2 kW 24 V | |
| Lifting speed with / without load | | Normal/quick: 8/26 mm per pump | 0,05 / 0,07 m/s | 0,05 / 0,07 m/s | 0,07 / 0,12 m/s | |
| Lowering speed with / without load | | Max 0,05 m/s - Max 0,07 m/s | 0,12 / 0,04 m/s | 0,12 / 0,04 m/s | 0,12 / 0,07 m/s | |
| Weight in kg (no battery) | | 400 kg | 430 kg | 430 kg | 480 kg | 485 kg |

* tests show that 1700 mm are enough.

** speed control electronically variable.